

General Specifications

Model UT351
Digital Indicating Controller
with Active Color PV Display



GS 05D01D12-01E

General

Model UT351 Digital Indicating Controller is a highly accurate 1/4 DIN controller, provided with the PV display color changing function "Active Color PV Display." It has a large display for readings, universal input/output and excellent monitoring operability with Auto/Man switching key. In addition, auto-tuning, the overshoot suppressing function "SUPER", the hunting suppressing function "SUPER2" and heating/cooling control are available as control functions, and a retransmission output and 15V DC loop power supply are also equipped as standard. A communication function or 24V DC loop power supply is available optionally. As described above, the UT351 is a controller provided with higher functions and capability.

Main Features

- Extra-large digital display allows the indicated values to be read even from a long distance. LEDs of 20mm height are used for the PV display.
- The PV display color changing function "Active Color PV Display" is provided. PV display color is changed from green to red and vice versa when an alarm occurs or deviation becomes large. The color also can be fixed in green or red.
- Universal input and output enable users to set or change freely the input type PV (thermocouple, RTD, or mV), PV input range, and type of control output(4 to 20mA current, voltage pulse, or relay contact) from the front panel.
- Parameters can easily be set using a personal computer. ("Parameter setting tool (model LL100)" sold separately is required.)
- Various communication functions are provided. Communication is possible with personal computer, programmable logic controller, and other controllers.

Functional Specifications

Control Computation Functions

Control computation:

Can be selected from the following types:
Continuous PID control, Time-proportional PID control, Heating/Cooling control (for heating/cooling type only) or Relay ON/OFF control.

Control cycle time: 250 ms

Number of sets of target setpoints and PID parameters: 4

Target setpoint and PID selection:

PID parameters are provided for every target setpoint and the set of PID parameters are selected at the same time that the setpoint number is selected.

Zone PID selection:

PID parameters are selected depending on the value of the PV. For selection, the reference point (PID parameter selection setpoint) or the reference deviation is used.

UT351

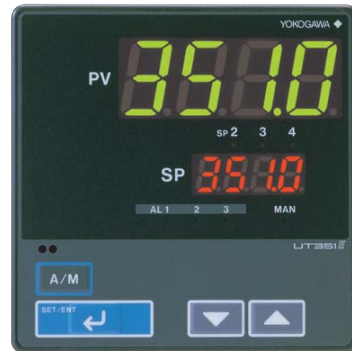

Indication in green or red color

UT351E

"E" indicates the model with expanded functions.

Reference point method:

The PV input range is divided into a maximum of three zones with up to two reference points, and PID parameters are selected (No. 1 PID to No. 3 PID) for every zone.

Reference point = PV input range (0%) \leq Reference point 1 \leq Reference point 2 \leq PV input range (100%)

Reference point hysteresis = Fixed to 0.5% of the PV input range span.

Reference deviation method:

PID parameters (No. 4 PID) are selected when the deviation exceeds the reference deviation. This process takes precedence over the reference point method.

Reference deviation = OFF or 0.1 to 100.0% of PV input range span

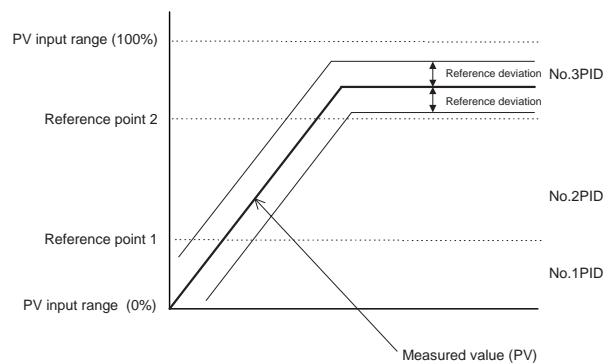

Auto-tuning:

Available as standard. If auto-tuning is operated, PID constants are automatically set (limit cycle method).

"SUPER" function:

Overshoots generated by abrupt changes in the target setpoint or by disturbances can be suppressed.

“SUPER2” function:

The function stabilizes the state of control that is unstable due to hunting, etc. without requiring any change in PID constants, when the load and/or gain varies greatly, or when there is a difference between the characteristics of temperature zones.

Control Parameters Setting Range

Proportional band = 0.1 to 999.9%

0.0 to 999.9% for heating/cooling control,
0.0% for ON/OFF control

Integral time = 1 to 6000s, or OFF (manual reset)

Derivative time = 1 to 6000s, or OFF

Manual reset value = -5.0 to 105.0% of output range
(functions when integral time is off.)

ON/OFF control hysteresis = 0.0 to 100.0% of PV input range span (0.1 to 0.5% for heating/cooling control)

Setpoint rate-of-change setting = OFF, or 0.0 to 100.0%/h or min of PV input range span.

A PV tracking function operates automatically when the setpoint is changed, the power is turned on, or the mode is changed from manual to automatic.

Direct/reverse action:

The output increase/decrease direction can be defined corresponding to a positive or negative deviation.

For heating/cooling control, it is fixed; for the heating side output, reverse, for the cooling side output, direct.

Anti-reset windup:

When controller output is limited, normal integration is superseded by an anti-reset windup computation to suppress over-integration.

Control output cycle time = 1 to 1000s for Time-proportional PID control (the cooling side output cycle time is also the same when heating/cooling control is used).

Preset output value = -5.0 to 105.0% of output range

Output tracking:

Whether the output bump is provided or not can be selected by changing the PID control mode.

Output limiter

Upper limit = Lower limit to 105.0% of output range

Lower limit = -5.0% of output range to upper limit

Heating/cooling dead band = -100.0 to 50.0% for output range

● Signal Computation Functions

PV input computation:

Bias addition (-100.0 to 100.0% of PV input range span), and first-order lag filter (time constant OFF or 1 to 120s)

Contact input function:

Target setpoint selection, Auto/Man operating mode switching, key lock parameter show/hide switching

Target setpoint selection can be done for either a 2-setpoint or 4-setpoint selection.

- If the 2-setpoint selection is set, Auto/Man mode switching can be used as well.

- If the 4-setpoint selection is set, Auto/Man switching and key lock parameter show/hide switching cannot be used together.

If key lock parameter show/hide switching is used, target setpoint selection and Auto/Man mode switching cannot be used.

● Alarm Functions

Twenty-four types of alarm functions are provided. The alarm status is indicated by the alarm lamp on the front panel. Also, three points among them can be output as relay contact outputs.

Alarm types:

PV high limit, PV low limit, Deviation high limit, Deviation low limit, De-energized on deviation high limit, De-energized on deviation low limit, Deviation high and low limits, High and low limits within deviation, De-energized on PV high limit, De-energized on PV low limit, SP high limit, SP low limit, Output high limit, Output low limit, Deviation high limit for target setpoint, Deviation low limit for target setpoint, De-energized on deviation high limit alarm for target setpoint, De-energized on deviation low limit alarm for target setpoint, Deviation high and low limits for target setpoint, Deviation within high and low limits for target setpoint, Heater burnout alarm, Sensor grounding alarm, Fault diagnostic alarm, and FAIL output.

Alarm output:

3 points. Any three points can be output as contact outputs among the above alarms. For heating/cooling control, if cooling side output is output as a relay contact, up to two alarm outputs can be used.

Setting ranges for PV, deviation, setpoint and output alarms:

PV/setpoint alarm:

-100.0 to 100.0% of PV input range

Deviation alarm:

-100.0 to 100.0% of PV input range span

Output alarm:

-5.0 to 105.0% of output range

Alarm hysteresis:

0.0 to 100.0% of PV input range span

Delay timer:

0.00 to 99.59 (minute, second)

An alarm is output when the delay timer expires after the alarm setpoint is reached.

Setting for each alarm is possible.

Stand-by action:

Stand-by action can be set to make PV/deviation alarm OFF during start-up or after SP change until SP reaches the normal region.

Heater burnout alarm (optional):

Two circuits incorporated.

A heater burnout alarm is output if the heater current consumption is the burnout detection value or less. This alarm can be used for Relay ON/OFF control or time-proportional PID control.

Heater current setting range: 0.0 to 50.0 A

Setting accuracy: $\pm 5\%$ of span ± 1 digit

Heater current detecting resolution: 0.5 A

Time required until burnout detection is on:

0.13s minimum

Burnout sensor model: CTL-6-S-H(URD Co. Ltd.)

Sensor grounding alarm:

An alarm is output after detecting a change in control output. If the moving average * of control output is out of the setting range (between the high and low limits of the on/off rate) in spite of the deviation being within a fixed range (on/off rate detection band) and control being in stable condition, the sensor is judged to be in a grounding condition.

* Moving average refers to the average value for output values sampled (five times) in every cycle time.

High- and low-limit setting range of on/off rate: -5.0 to 105.0% of output range

Detection band of on/off rate: 0.0 to 100.0% of PV input range span.

Fault diagnostic alarm:

Input burnout, A/D conversion error, thermocouple reference junction compensation error

FAIL output:

Abnormality in software or hardware. When in FAIL, control output, retransmission output and alarm output become 0% or OFF.

● Display and Operation Functions

PV display: 4-digit digital display for engineering data

Setpoint display:

Various data, such as the setpoint (SP), are displayed by selection on the 4-digit digital display.

Status indicating lamps:

3 alarm indicator lamps: AL1, AL2, AL3

3 setpoint number indicator lamps: SP2, SP3, SP4 (Go out when SP1 is selected.)

MAN operation mode lamp:

MAN (Lit in MAN mode.)

PV display color changing function “Active Color PV Display” :

(Factory-set default : Fixed in red mode)

This function automatically changes PV display color by the action described below. Green-to-red or red-to-green changing action is selectable.

Link to alarm 1 mode :

Alarm OFF : green, Alarm ON : red
Setting of Alarm OFF : red, Alarm ON : green is possible.

Link to alarms 1 and 2 mode :

Alarm OFF : green, Alarm ON : red
Setting of Alarm OFF : red, Alarm ON : green is possible.

SP deviation mode :

Within the preset SP deviation : green,
Out of the preset SP deviation : red
Setting of within the preset SP deviation : red,
Out of the preset SP deviation : green is possible.
Deviation band is changeable using a parameter. The setting of either high limit deviation or low limit deviation is also possible.

PV limit mode :

Within the preset PV range : green,
Out of the preset PV range : red
Setting of within the preset PV range : red,
Out of the preset PV range : green is possible.
The range (high limit and low limit) is changeable using a parameter.

Fixed color mode :

PV display color is fixed in green or red.

Operation keys:

△ and ▽ keys:

Increase or decrease setpoints and various parameters.

SET/ENT key:

Used for data setting or call-up/selection of various parameters

A/M key:

Switching of operation mode (Auto/Man)

SELECT display:

A panel where operating parameters that are frequently changed during operation can be selected and registered. For example, by registering the alarm -1 setpoint in the SELECT display, the setpoint can easily be displayed during operation.

Security function:

An operation-inhibiting mode using a password is provided.

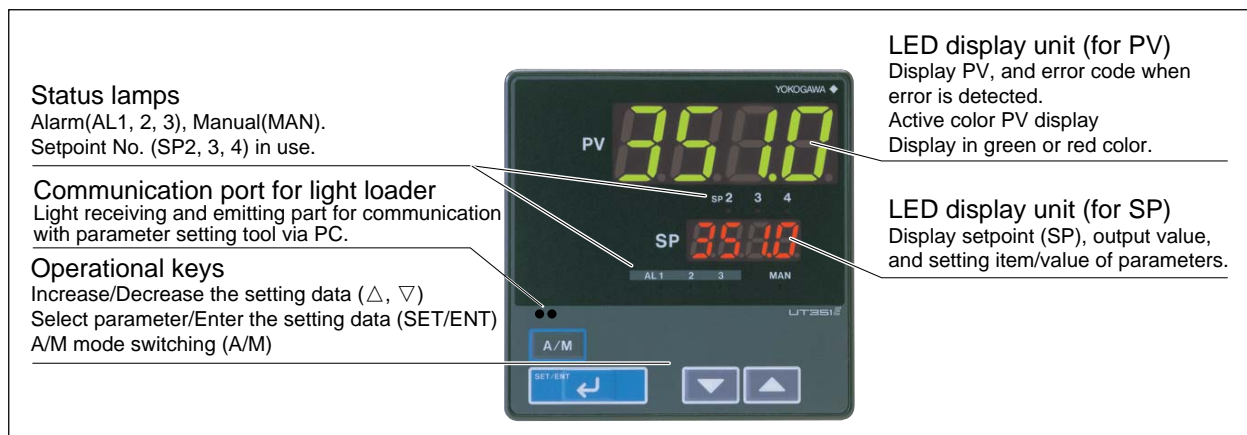

● **Communication Functions(optional)**

This controller has a communication function and can be connected to a personal computer, programmable logic controller or other GREEN series controllers.

Communication protocol

Computer link communication:

Communication protocol with a personal computer.

Ladder communication:

Communication protocol with programmable logic controller.

MODBUS communication:

Communication protocol with a personal computer or PLC.

Coordinated operation:

Communication protocol to coordinated operation with two or more GREEN series controllers. The UT351 can be connected as a master station or a slave station.

Communication interface

Communication protocol:

Computer link, ladder communication, MODBUS or coordinated operation.

Standards: EIA RS485

Maximum number of connectable controllers:

31 GREEN series controllers

Maximum communication distance: 1,200 m

Communication method:

Two-wire half duplex or four-wire half duplex, start-stop synchronization, non-procedural.

Communication rate: 600, 1200, 2400, 4800, or 9600 bps

Examples of Communication System Configuration Diagram

(1) Computer link communication/MODBUS communication

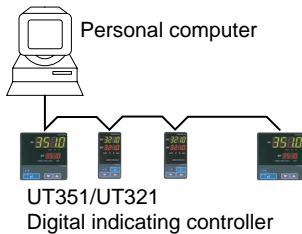

(2) Ladder communication

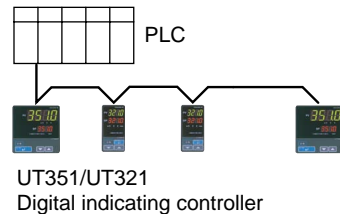

(3) Coordinated operation

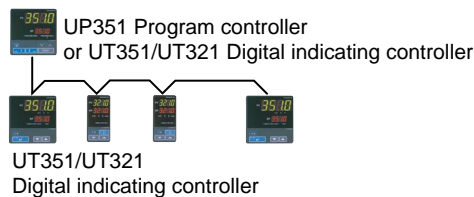

Hardware Specifications

PV Input Signal

Number of input points: 1

Input system:

The type of input and instrument range can be specified using the table of PV input shown below by key operation or communication.

Input type, instrument range and measurement accuracy:

Refer to the table below.

Input Type		Input range code	Instrument range (°C)	Instrument range (°F)	Measurement accuracy*1
Unspecified(when shipped from the factory)		OFF	Set the data item PV input Type"IN" to the OFF option to leave the PV input type undefined.		
Thermocouple	K	1	-200 to 1370°C	-300 to 2500°F	±0.1% of instrument range ±1 digit for temperatures equal to or higher than 0 °C, ±0.2% of instrument range ±1 digit for temperatures below 0 °C
		2	-199.9 to 999.9°C	0 to 2300°F	
		3	-199.9 to 500.0°C	-199.9 to 999.9°F	
	J	4	-199.9 to 999.9°C	-300 to 2300°F	
	T	5	-199.9 to 400.0°C	-300 to 750°F	
		6	0.0 to 400.0°C	-199.9 to 750.0°F	
	B	7	0 to 1800°C	32 to 3300°F	±0.15% of instrument range ±1 digit for temperatures equal to or higher than 400 °C ±5% of instrument range ±1 digit for temperatures below 400 °C
	S	8	0 to 1700°C	32 to 3100°F	±0.15% of instrument range ±1 digit
	R	9	0 to 1700°C	32 to 3100°F	
	N	10	-200 to 1300°C	-300 to 2400°F	±0.1% of instrument range ±1 digit ±0.25% of instrument range ±1 digit for temperature below 0 °C
	E	11	-199.9 to 999.9°C	-300 to 1800°F	±0.1% of instrument range ±1 digit for temperatures equal to or higher than 0 °C
	L (DIN)	12	-199.9 to 900.0°C	-300 to 1300°F	
	U (DIN)	13	-199.9 to 400.0°C	-300 to 750°F	±0.2% of instrument range ±1 digit for temperatures below 0 °C
		14	0.0 to 400.0°C	-199.9 to 750.0°F	
	W (DIN)	15	0 to 2300°C	32 to 4200°F	±0.2% of instrument range ±1 digit
	Platinel 2	16	0 to 1390°C	32 to 2500°F	±0.1% of instrument range ±1 digit
	PR20-40	17	0 to 1900°C	32 to 3400°F	±0.5% of instrument range ±1 digit for temperatures equal to or higher than 800 °C No guarantee of accuracy for temperatures below 800 °C
	W97Re3-W75Re25	18	0 to 2000°C	32 to 3600°F	±0.2% of instrument range ±1 digit
RTD	JPt100	30	-199.9 to 500.0°C	-199.9 to 999.9°F	±0.1% of instrument range ±1 digit (Note 1) (Note 2)
		31	-150.0 to 150.0°C	-199.9 to 300.0°F	±0.2% of instrument range ±1 digit (Note 1)
	Pt100	35	-199.9 to 850.0°C	-300 to 1560°F	±0.1% of instrument range ±1 digit (Note 1) (Note 2)
		36	-199.9 to 500.0°C	-199.9 to 999.9°F	
		37	-150.0 to 150.0°C	-199.9 to 300.0°F	±0.2% of instrument range ±1 digit (Note 1)
Standard signal	0.4 to 2V	40	0.400 to 2.000	Scaling is enable in the following 4 range.	±0.1% of instrument range ±1 digit The read-out range can be scaled between -1999 and 9999.
	1 to 5V	41	1.000 to 5.000		
DC voltage	0 to 2V	50	0.000 to 2.000	-1999 to 9999	
	0 to 10V	51	0.00 to 10.00	-199.9 to 999.9	
	-10 to 20mV	55	-10.00 to 20.00	-19.99 to 99.99	
	0 to 100mV	56	0.0 to 100.0	-1.999 to 9.999	

Note 1: The accuracy is ±0.3°C of instrument range ±1 digit for a temperature range from 0 to 100°C.

Note 2: The accuracy is ±0.5°C of instrument range ±1 digit for a temperature range from -100 to 0°C and 100 to 200°C.

*1: Performance in the standard operating condition (at 23°C ±2°C, 55±10%RH, and 50/60Hz power frequency)

*2: To receive a 4 to 20 mA DC signal, select a Standard signal of 1 to 5 V DC and connect it to a 250 Ω resistor.

This resistor is optional Model: X010-250-2 (resistor with M3.5 crimp-on-terminal lugs)

Sampling period: 250 ms

Burnout detection:

Functions with a thermocouple (TC), RTD, standard signal 0.4 to 2 V DC, and 1 to 5 V DC. Can be specified as upscale, downscale, and off. For standard signal, judged as burnout at 0.1 V or less.

Input bias current: 0.05 μA (for TC/RTD b-terminal)

Measuring current(RTD): about 0.13mA

Input resistance:

1 MΩ or more for TC/mV input
About 1 MΩ for DC voltage input

Allowable signal source resistance:

250 Ω or less; effect of permissible signal source resistance 0.1 μV/Ω or less for TC/mV input 2 k Ω or less; effect of permissible signal source resistance 0.01%/100 Ω or less for DC voltage input

Allowable leadwire resistance:

Max. of 150 Ω/wire (resistance in each of three wires must be equal) for RTD input However, 10 Ω/wire for a maximum range of -150.0 to 150.0°C. Effect of permissible leadwire resistance ± 0.1°C/10 Ω or less

Allowable input voltage:
 ± 10 V DC for TC/mV/RTD input
 ± 20 V DC for DC voltage input

Noise rejection ratio:
 Normal mode 40 dB (50/60 Hz) or more
 Common mode 120 dB (50/60 Hz) or more

Reference-junction compensation error:
 ± 1.0°C (15 to 35°C),
 ± 1.5°C (0 to 15°C, 35 to 50°C)

Applicable standards: JIS, IEC, or DIN(ITS-90) for TC and RTD

Response time: 2 second or less, 63% (10 - 90%)
 (The time required for transmission output to reach 63% of the maximum excursion when PV abruptly changes from 10% to 90%)

24V DC Loop Power Supply for Sensor

The controller supplies power to a two-wire transmitter. Place a resistor (10 to 250Ω) between the controller and the transmitter, convert a current signal to a voltage signal, and read it from the PV input.

21.6 to 28.0 V DC, maximum supply current is about 30mA (only for models with 24V DC\ loop power supply).

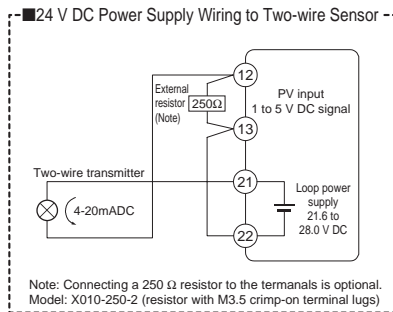

Retransmission Output

Either PV, target setpoint, or control output is output. Either the retransmission output or the 15V DC loop power supply can be used.

Number of output points: 1
 Output signal: 4 to 20 mA DC
 Load resistance: 600 Ω or less
 Output accuracy: ± 0.3% of span
 * Performance in the standard operating conditions (at 23± 2°C, 55± 10% RH, and 50/60 Hz power frequency)

15V DC loop power supply:

Supply voltage is 14.5 to 18.0 V DC. Maximum supply current is about 21 mA (with a protection circuit for a field short-circuit).

Control Outputs

The control output is of a universal scheme and can be selected from the following types of outputs. In the case of heating/cooling control, it is also selectable from these outputs. However, if the cooling side output is a relay contact output, the alarm-3 cannot be used, and similarly if the cooling side output is a voltage pulse or current output, the retransmission output/15 V DC sensor power supply cannot be used.

Current output
 Number of output points: 1 or 2 (2 for heating/cooling type) switchable to voltage pulse output.
 Output signal: 4 to 20 mA
 Load resistance: 600 Ω or less
 Output accuracy: ±0.3% of span
 * Performance in the standard operating conditions (at 23± 2°C, 55± 10% RH, and 50/60 Hz power frequency)

Voltage pulse output
 Number of output points: 1 or 2 (2 for heating/cooling type) switchable to voltage pulse output.
Output signal:
 On voltage = 12 V DC or more (load resistance of 600 Ω or more; current on short-circuiting about 30 mA)
 Off voltage = 0.1 V DC or less
Resolution: 10 ms
Relay contact output
 Number of output points: 1 or 2 (2 for heating/cooling type)
Output signal:
 Three terminals for NC, NO, and Common transfer-contact
Contact rating:
 250V AC, 3 A or 30V DC, 3A (resistive load)
Resolution: 10 ms

Contact Inputs

Usage: Target setpoint selection, Auto/Man mode switching, or Key lock parameter show/hide switching
Number of input points: 2
Input type: Non-voltage contact input or transistor open collector input
Input contact rating: 12 V DC, 10 mA or more (for non-voltage contact input)
On/off determination:
 For non-voltage contact input,
 ON = contact resistance of 1 kΩ or less,
 OFF = contact resistance of 20 kΩ or more.
 For transistor contact input,
 ON = 2 V or less,
 OFF = leakage current of 100 μA or less.
Minimum retention time for status detection: about 1 second

Contact Outputs

Usage: Alarm output, FAIL output, and others
Number of relay contact output points: 3
Relay contact rating: 240 V AC, 1 A or 30 V DC, 1 A (COM terminal is common for every contact output.)

● **Display Specifications**

PV display: 4-digit, 7-segment green or red LED; character height - 20 mm
Setpoint display: 4-digit, 7-segment red LED; character height - 9.3 mm
Status indicating lamps: LEDs

● **Conformance to Safety and EMC Standards**

Safety: Complies with IEC/EN61010-1 (CE), approved by C22.2 No.61010-1, approved by UL508.
 Installation category : CAT. II Pollution degree: 2 (IEC/EN61010-1, C22.2 No.61010-1)
 Measurement category : I (CAT. I : IEC/EN61010-1)
 Rated measurement input voltage : 10V DC max.(across terminals), 300V AC max.(across ground)
 Rated transient overvoltage : 1500V (Note)
 Note : It is a value on the safety standard which is assumed by IEC/EN61010-1 in Measurement category I, and is not the value which guarantees an apparatus performance.
EMC standards: Complies with EN61326, EN61000-3-2, EN61000-3-3 and EN55011 (CE). AS/NZS 2064 compliant (C-Tick).
 Class A Group 1.
 During test, the controller continues to operate with the measurement accuracy within ±20% of the range.

● Construction, Mounting, and Wiring

- Construction: Dust-proof and Drip-proof front panel conforming to IP55.
For side-by-side close installation, the controller loses its dust-proof and drip-proof protection.
- Material: ABS resin and polycarbonate
Case color: Black
Weight: Approx. 1 kg or less
External dimensions:
96 (width) × 96 (height) × 100 (depth) mm
- Mounting : Direct panel mounting; mounting bracket, one each for upper and lower mounting
- Panel cutout dimensions: $92_{-0}^{+0.8}$ (width) × $92_{-0}^{+0.8}$ (height) mm
Mounting attitude:
Up to 30 degrees above the horizontal. No downward tilting allowed.
- Wiring:
M3.5 (ISO 3.5 mm) screw terminals (signal wiring and power/ground wiring as well)

● Power Supply Specifications and Isolation

- Power supply: Rated at 100 to 240 V AC ($\pm 10\%$), 50/60 Hz
Power consumption: MAX. 20 VA (MAX. 8.0 W)
Internal fuse rating: 250 VAC, 1.6A time-lag fuse
Memory back-up: Non-volatile memory (Service life approx. 100,000 times of writings)
- Withstanding voltage:
1500 V AC for 1 minute between primary and secondary terminals.
1500 V AC for 1 minute between primary and ground terminals.
1500 V AC for 1 minute between ground and secondary terminals.
500VAC for 1 minute between two secondary terminals.

(Primary terminals = Power and relay output terminals)
(Secondary terminals = Analog I/O signal terminals, voltage pulse output terminals, contact input terminals)

- Isolation resistance:
20 M Ω or more when 500 V DC voltage is applied between the power terminals and ground terminal.

- Grounding:
Class D grounding (Class 3 grounding)
(grounding resistance of 100 Ω or less)

● Isolation specifications:

- PV input terminal:
Isolated from other I/O terminals. Not isolated from internal circuits.
- 15 V DC loop power supply terminals:
Not isolated from 4-20mA analog output and voltage pulse control output. Isolated from other I/O terminals and internal circuit.
- 24 V DC loop power supply terminals:
Isolated from other I/O terminals and internal circuit.
- Control output (current or voltage pulse) and retransmission terminals: Not isolated between control output terminals and retransmission output terminals. Isolated from other I/O terminals and internal circuits.
- Relay contact control output terminals:
Isolated from other I/O terminals and internal circuits.
- Contact input terminals:
Not isolated from other contact input terminals mutually, and communication terminals. Isolated from other I/O terminals and internal circuits.
- Relay contact alarm output terminals:
Isolated from other I/O terminals and internal circuits.
- RS-485 communication terminals:
Not isolated from contact input terminals. Isolated from other I/O terminals and internal circuits.
- Power supply terminals:
Isolated from other I/O terminals, ground terminal, and internal circuits.
- Ground terminal:
Isolated from other I/O terminals, power terminals, and internal circuits.

● Environmental Conditions

- Normal operating conditions:
Ambient temperature: 0 to 50°C (40°C or less for mounting of instruments side-by-side)
Ambient temperature change limit: 10°C /h or less
Ambient humidity: 20 to 90% RH (no condensing)
Magnetic field: 400 A/m or less
Continuous vibration (5 to 14 Hz):
Peak-to-peak amplitude of 1.2 mm or less
Continuous vibration (14 to 150 Hz):
4.9 m/s² or less
Short-period vibration: 14.7 m/s², 15s or less
Shock: 147 m/s² or less, 11 ms
Installation altitude: 2,000 m or less above sea level
Warm-up time 30 minutes or more
- Transportation and storage conditions:
Temperature: -25 to 70°C
Temperature change limit: 20°C /h or less
Humidity: 5 to 95% RH
- Effects of operating conditions
Effect of ambient temperature:
For voltage or TC inputs:
Whichever is greater, $\pm 1\mu\text{V}/^\circ\text{C}$ or $\pm 0.01\%$ of F.S./ $^\circ\text{C}$
For RTD inputs:
 $\pm 0.05^\circ\text{C}/^\circ\text{C}$ (ambient temperature) or less for RTD input
For analog output: $\pm 0.05\%$ of F.S./ $^\circ\text{C}$ or less
Effect of power supply fluctuation (within rated voltage range):
For analog input:
Equal to or less than whichever is greater, $\pm 1\mu\text{V}/10\text{ V}$ or $\pm 0.01\%$ of F.S./10 V
For analog output: $\pm 0.05\%$ of F.S./10 V or less

Function Block Diagram for Standard Type

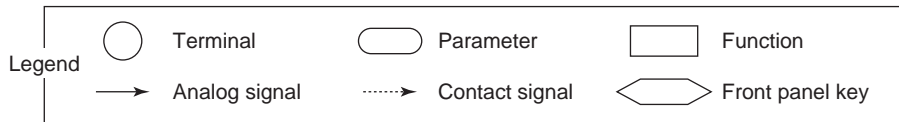
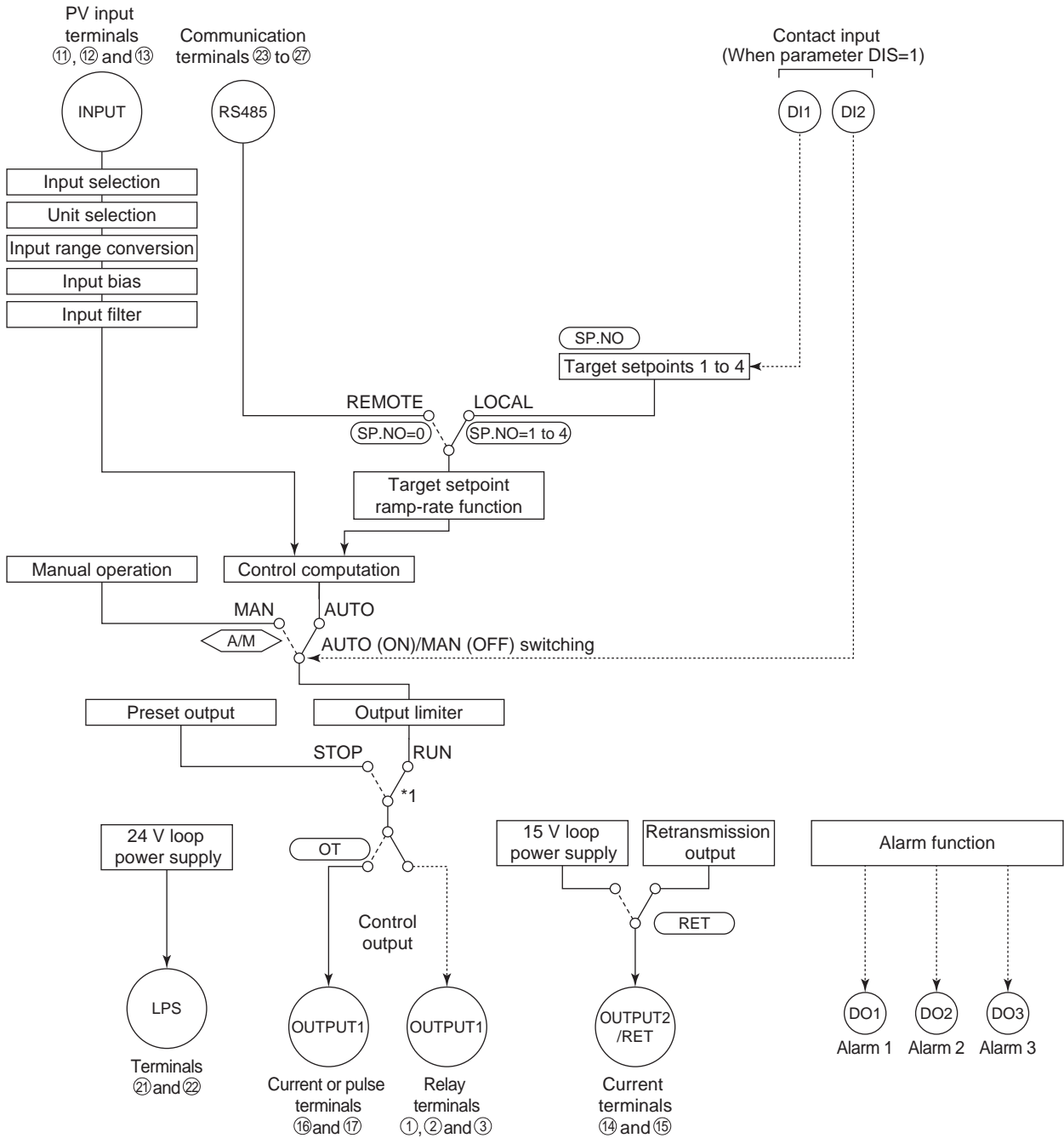

Function Block Diagram for Heating/Cooling Type

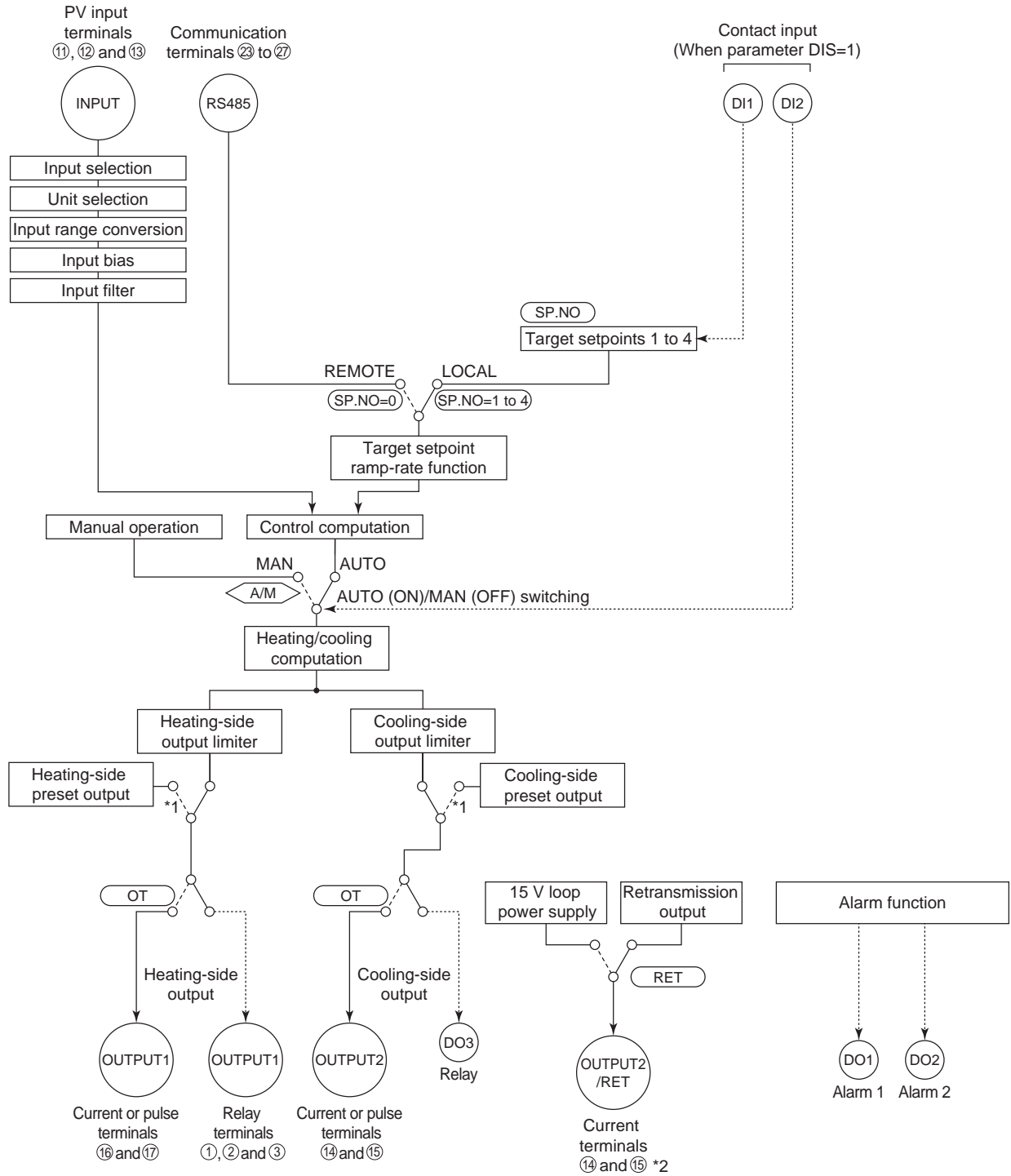

*1: If the setup parameter DIS (DI function selection) is set to 4 ,
when the contact input 2 is ON (STOP state), that controller outputs the preset output value.
*2: Unavailable when cooling-side control output is current or pulse.



Standard Type, Terminal Arrangements

Control output
Relay contact output
NC NO COM
Contact rating: 250 V AC, 3 A
30 V DC, 3 A (resistance load)

Alarm output
AL1 AL2 AL3 COM
Relay contact rating: 240 V AC, 1 A
30 V DC, 1 A (resistance load)

Power supply
L N 10
Allowable range: 100 to 240 V AC (±10%)
(free voltage)
50/60 Hz shared

CAUTION
Before carrying out wiring, turn off the power to the controller and check that cables to be connected are not energized to avoid electric shock.

RS-485 communication
23 SDB(+) 24 SDA(-) 25 RDB(+) 26 RDA(-) 27 SG

* Wiring can only be carried out for controllers with communication functions.
Maximum baud rate: 9600 bps

24 V DC loop power supply
21 22
24 V DC loop power supply
21.6-28.0V DC (30 mA DC max.)

* Wiring can only be carried out for controllers with 24 V DC loop power supply.

PV input * Not configured at factory before shipment

TC input
12 13
m/V/V input
12 13

* PV retransmission is configured at factory before shipment.

Receiving 4-20 mA DC Current Signals with the Controller
* When receiving 4-20 mA DC current signals, set the PV input type to 1-5 V DC (setpoint "4.1").

Note: Connecting a 250 Ω resistor to the terminals is optional.
Model: X010-250-2 (resistor with M3.5 crimp-on terminal lugs)

Control output Current/voltage pulse output
16 17
4-20 mA DC, voltage pulse (12 V)

Note: Select this option from the OT parameter.

External contact input functions

When DIS=1 (Factory-shipped setting)	When DIS=2	When DIS=3	When DIS=4
No function	Hides the LOCK parameter when DI1=ON 1.SP when DI1=OFF	1.SP to 4. 1.SP:SP:SP:SP	2.SP when DI1=ON 1.SP when DI1=OFF
No function	AUTO when DI2=ON MAN when DI2=OFF	DI1 OFF ON OFF ON DI2 OFF OFF ON ON	STOP when DI2=ON RUN when DI2=OFF
Common	Common	Common	Common

* DIS is a setup parameter.
Changing DIS setpoint allows you to change the function of external contact input.

Heater current detection input
29 CT1 28 CT2 30 COM

* This wiring is only possible for a controller with a heater burnout alarm.

External Contact Input
Note: External Contact Input
If the power is turned on when the external contact input is OFF, the mode (SP:NO or AM) existing before the power is turned off will be continued.
(except for RUN/STOP)

Contact rating: 12 V DC, 10 mA or more

Correspondence between parameter OT and control output types

OT=0 (factory-shipped setting)	OT=1	OT=2	OT=3
Time proportional control Relay output (terminals ①, ② and ③)	Time proportional control Voltage pulse output (terminals ⑥ and ⑦)	Current output (terminals ⑩ and ⑪)	On-off control Relay output (terminals ①, ② and ③)

Heating/Cooling Type, Terminal Arrangements

Receiving 4-20 mA DC Current - Signals with the Controller

* When receiving 4-20 mA DC current signals, set the PV input type to 4-5 V DC (setpoint "41").

Note: Connecting a 250 Ω resistor to the terminals is optional.
Model: X010-250-2 (resistor with M3.5 crimp-on terminal lugs)

PV input * Not configured at factory before shipment

RTD input

mV/V input

Receiving 4-20 mA DC Current - Retransmission output

* PV retransmission is configured at factory before shipment.

Retransmission output

* If 15 V DC loop power supply is used, retransmission output cannot be used.

Heating-side control output

* Available if 5, 6, 8, 9, 11 or 12 is set in the OT (Control Output Type) setup parameter.

Heating-side control output (Control Output Type) setup parameter.

Heating-side control output

* Available if 5, 6, 8, 9, 11 or 12 is set in the OT (Control Output Type) setup parameter.

Heating-side control output (Control Output Type) setup parameter.

Power supply

CAUTION

Before carrying out wiring, turn off the power to the controller and check that cables to be connected are not alive with a tester or the like because there is a possibility of electric shock.

Allowable range: 100 to 240 V AC (±10%) (free voltage) 50/60 Hz shared

Heater current detection input

* This wiring is only possible for a controller with a heater burnout alarm.

RS-485 communication

* Wiring can only be carried out for controllers with communication functions.
Maximum baud rate: 9600 bps

External Contact Input

If the power is turned on when the external contact input is OFF, the mode (SP NO or AM) existing before the power is turned off will be continued. (except for RUN/STOP)

Contact rating: 12 V DC, 10 mA or more

Relay contact output

* Time proportional PID relay contact output is configured at factory before shipment.
* Available if 4, 7 or 10 is set in the OT (Control Output Type) setup parameter.

Contact rating: 250 V AC, 3 A (resistance load)
30 V DC, 3 A (resistance load)

Relay contact output

* Time proportional PID relay contact output is configured at factory before shipment.
* Available if 4, 7 or 10 is set in the OT (Control Output Type) setup parameter.

Contact rating: 250 V AC, 3 A (resistance load)
30 V DC, 3 A (resistance load)

Alarm output/cooling-side control output

Relay contact rating: 240 V AC, 1 A (resistance load)
30 V DC, 1 A (resistance load)

Note: The cooling-side control output is selected if 4, 5 or 6 is set in the OT (Control Output Type) setup parameter.
The alarm-3 output is not available.
The controller is factory-set to the cooling-side control output (time proportional PID relay contact output).

Correspondence between parameter DIS and external contact input functions

When switching target SP 1 to 4	When DIS-1 (Factory-shipped setting)	When DIS-2	When DIS-3	When DIS-4	Common
DI OFF ON OFF ON	2.SP when DI=ON 1.SP when DI=OFF	Hides the LOCK parameter when DI=ON Shows the LOCK parameter when DI=OFF	When DI=ON 2.SP when DI=OFF 1.SP when DI=ON	When DI=ON 2.SP when DI=OFF 1.SP when DI=ON	Common
DI OFF ON OFF ON	No function	No function	AUTO when DI=ON MAN when DI=OFF	Common	Common
DI OFF ON OFF ON	Common	Common	Common	Common	Common

Terminal Arrangements

OT=4 (factory-shipped setting)

Heating side: Relay output (terminals ①, ② and ③)
Cooling side: Relay output (terminals ④ and ⑤)

OT=5

Heating side: Voltage pulse output (terminals ⑥ and ⑦)
Cooling side: Voltage pulse output (terminals ⑧ and ⑨)

OT=6

Heating side: Current output (terminals ⑩ and ⑪)
Cooling side: Relay output (terminals ⑫ and ⑬)

OT=7

Heating side: Relay output (terminals ⑭ and ⑮)
Cooling side: Voltage pulse output (terminals ⑯ and ⑰)

OT=8

Heating side: Voltage pulse output (terminals ⑱ and ⑲)
Cooling side: Voltage pulse output (terminals ⑳ and ㉑)

OT=9

Heating side: Current output (terminals ㉒ and ㉓)
Cooling side: Voltage pulse output (terminals ㉔ and ㉕)

OT=10

Heating side: Relay output (terminals ㉖ and ㉗)
Cooling side: Current output (terminals ㉘ and ㉙)

OT=11

Heating side: Voltage pulse output (terminals ㉚ and ㉛)
Cooling side: Current output (terminals ㉜ and ㉝)

OT=12

Heating side: Current output (terminals ㉞ and ㉟)
Cooling side: Current output (terminals ㊱ and ㊲)

The control output types, "relay output" and "voltage pulse output" shown in the table above refer to those of time proportional control. To change the type to a relay output for on-off control, select "Relay Terminals" and change the setpoint of the proportional band to "0."

All Rights Reserved. Copyright © 2002, Yokogawa Electric Corporation

GS 05D01D12-01E

6th Edition Apr. 02, 2007-00

External Dimensions and Panel Cutout Dimensions

Unit: mm

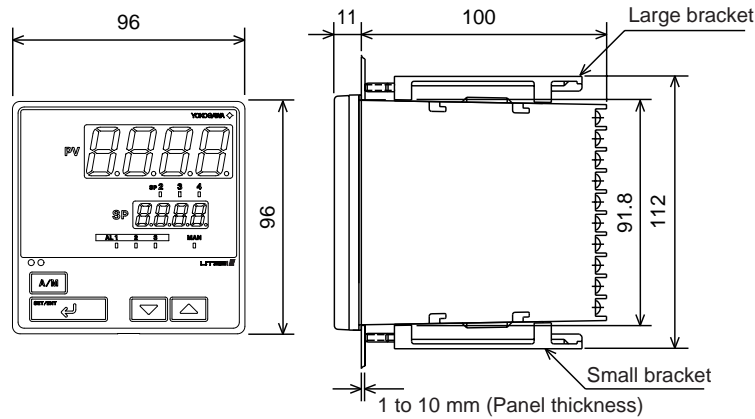

General installation

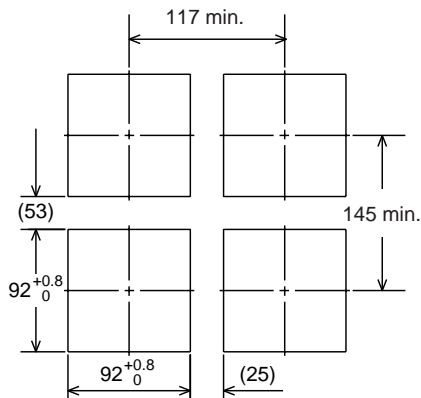

Side-by-side close installation

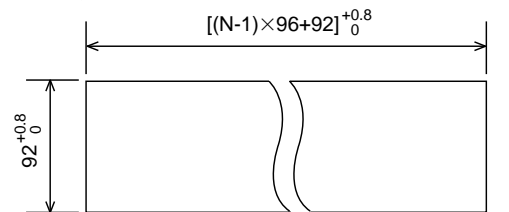

"N" stands for the number of controllers to be installed.
However, the measured value applies if $N \geq 5$.

Normal Allowable Deviation=± (Value of JIS B 0401-1999 tolerance grade IT18) / 2

Model and Suffix codes

Model	Suffix Code	Description
UT351		Digital indicating controller (provided with retransmission output and 15 V DC loop power supply as standard)
Type	-0 -2 -3	Standard type Heating/cooling type Standard type (with 24 V DC loop power supply)
Optional functions	0 1 2	None With communication, heater burnout alarm With heater burnout alarm

Standard Accessories: Brackets (mounting hardware), unit label, User's Manuals, and User's Manual (reference) (CD-ROM version)
Terminal cover (optional part) is provided.

Items to be Specified when Ordering

Model and suffix codes, necessary/unnecessary of User's Manual or QIC.